

REVISIONS				
ZONE	REV	DESCRIPTION	DATE	APPROVED
	1	New Release	12-15-09	R. Denney
	2	Dimension Verification	8-1-17	R. Denney

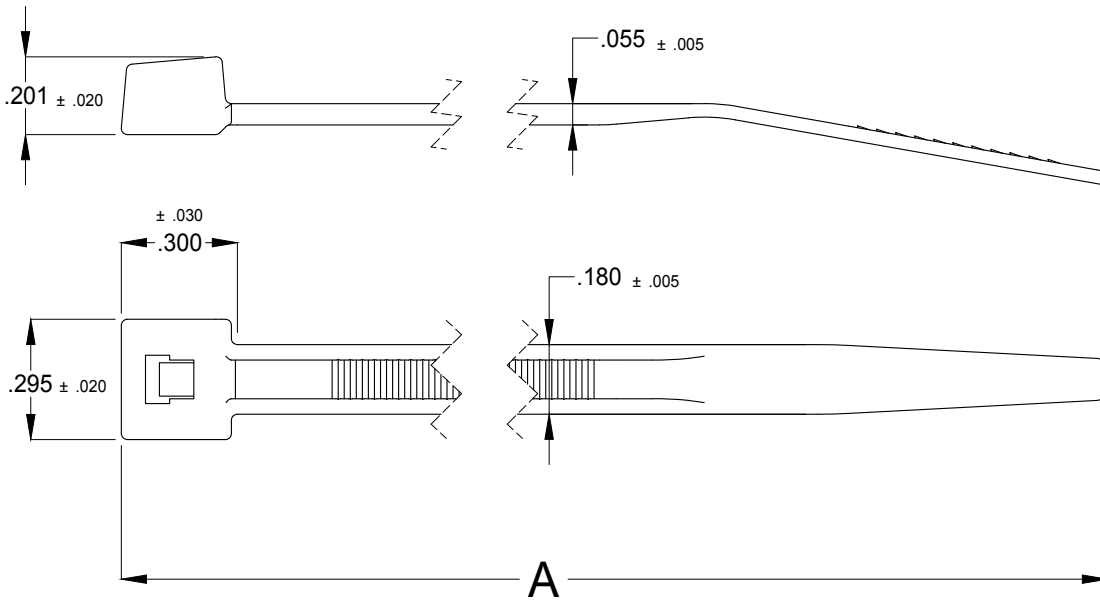

NOTES:

1. MINIMUM TENSILE RATING: 50 LBS (222N)
2. MINIMUM BUNDLE DIA: 0.325
3. MAXIMUM BUNDLE DIA: (SEE TABLE)

AEM No. / MIL SPEC	MAXIMUM BUNDLE DIA.	A
B7S* ** (MS3367-1-*)	1.875	7.6
B11S* ** (MS3367-7-*)	3.0	11.1
B14S* ** (MS3367-2-*)	4.0	14.6
B17S**	5.0	17.1

\* = NUMBER/COLOR

- |            |                        |  |
|------------|------------------------|--|
| 0 - Black  | 6 - Blue               | 12 - Fluorescent Pink                      |
| 1 - Brown  | 7 - Purple             | 13 - Fluorescent Yellow                    |
| 2 - Red    | 8 - Gray               | 14 - Fluorescent Orange                    |
| 3 - Orange | 9 - Natural            | 15 - Fluorescent Blue                      |
| 4 - Yellow | 10 - White             | HS - Heat Stabilized                       |
| 5 - Green  | 11 - Fluorescent Green | AH - Air Handling (NEC 300-22 (C) and (D)) |

<p>** = PACKAGE M = 1,000 D = 500 H = 250 C = 100 L = 50 Q = 25</p> <p>ALL DIMENSIONS ARE FOR REFERENCE ONLY UNLESS SPECIFIED, ALL MEASUREMENTS ARE IN INCHES</p>	<b>AMERICAN ELITE MOLDING, LLC</b>			
	Standard (Std) Cable Tie 50 LB (222 N) Series			
	SIZE <b>A</b>	FSCM NO.	DWG. NO. <b>B7-11-14-17S</b>	REV <b>2</b>
SCALE <b>N/A</b>	Material Nylon 6/6		SHEET <b>1 of 1</b>	